

LEVEL GAUGES

WATER

Lunkenheimer 200 lb water gauges are made of ASTM B61 type S-1 steam bronze. They are non-automatic. Needle type drain valves in lower bodies have plain nose outlet and 1/4" pipe threaded male inlet.

Lunkenheimer 300 lb water

gauges have bodies of ASTM B61 Type S-1 steam bronze.

Automatic hand-operated valves are supplemented in upper and lower bodies by ball check valves which close if glass is broken, allowing operator a safe approach to shut off valve.

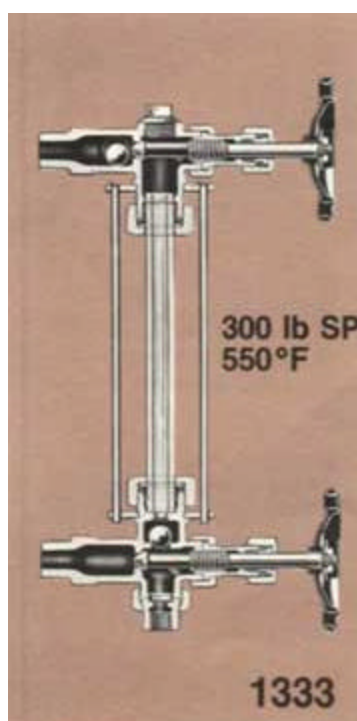
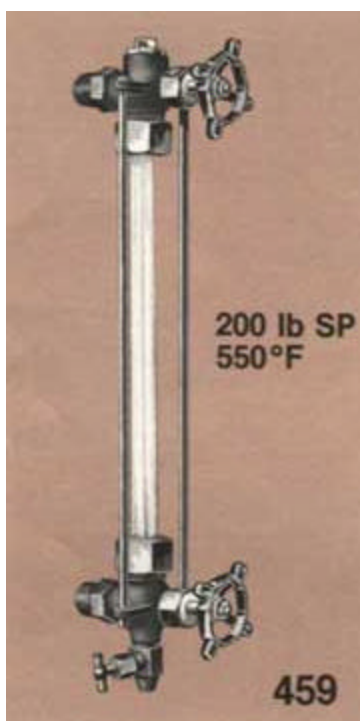

Dimensions in inches/Weights in pounds	459	459	1333	1333
Size	1/2 Pipe 5/8 Glass	3/4 Pipe 3/4 Glass	1/2 -Inch Pipe x 3/4 -Inch Glass	3/4 -Inch Pipe x 3/4 -Inch Glass
Distance between Centers	(18-inch is standard. Specify other distance desired.)			
Outside Diameter Glass	5/8	3/4	3/4	3/4
Length Glass for 18-inch Centers	16 1/2	16	15 3/8	15 3/8
Length Rods for 18-inch Centers	18 7/16	18 7/16	15 15/16	15 15/16
Weights	2.3	3.8	6.1	6.7

